

# Weber Knapp Co. Flat Screen Support System Capacities for Monitor Weight

(1) arm per Monitor

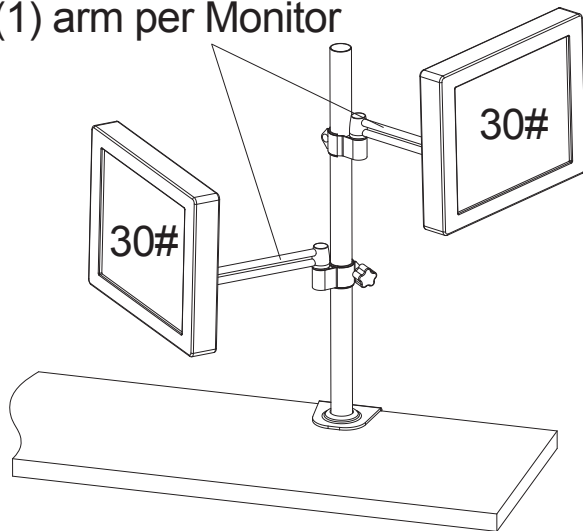

(2) arms

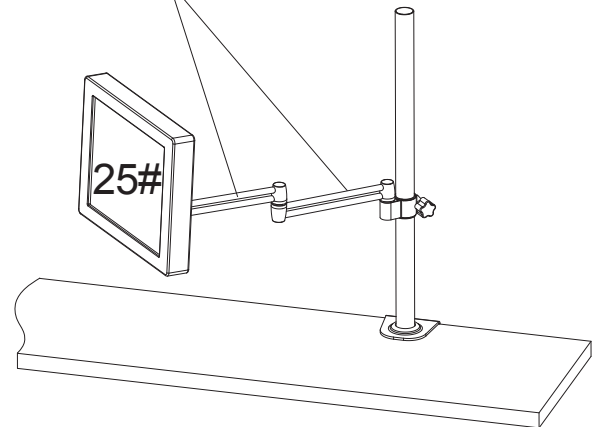

single arm

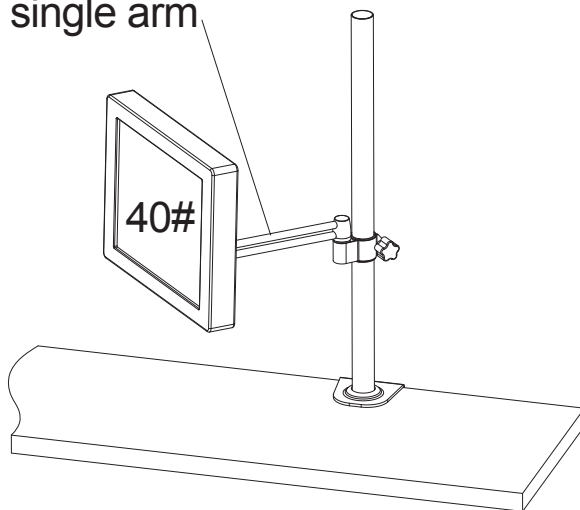

No arms

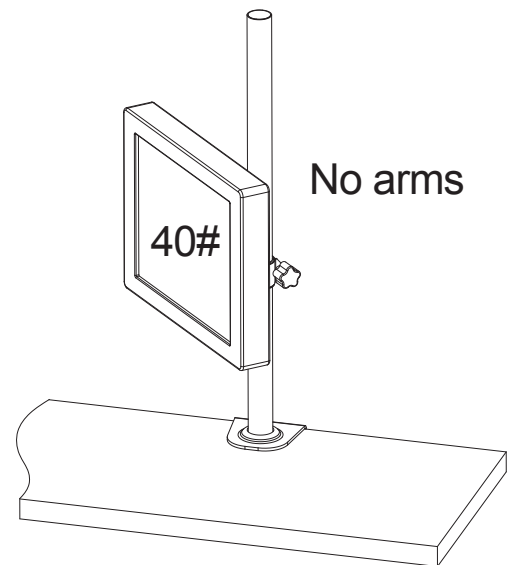

- Any configuration greater than 2 monitors, or weights exceeding values shown, contact Weber Knapp Co. Product Design Department - (716) 484-9135, ext. 202.
- Recommended capacities are dependent on worksurface strength, which may vary with application.
- Test worksurface was 45# density, 1" particle board with single laminate on top surface.
- All values apply to Grommet Mount and Clamp Mount.
- **WARNING:** For Clamp style mounting, monitors should not be rotated behind the worksurface.